

d.RS485/RS232 Control:

The control output port is connected to an RJ45 (8P8C) plug, with lines 1 and 2 being the control lines. For RS485 control connection, line 1 is D-, and line 2 is D+. For RS232 control connection, please refer to the diagram shown:

RS485/RS232 port settings:

- Baud rate: 2400;
- Data bits: 8 bits;
- Parity: None;
- Stop bits: 1

Hexadecimal control codes:

- Retract: FF EE EE EE DD
- Stop: FF EE EE EE CC
- Extend: FF EE EE EE EE

Some central control devices require an address code to be set:
FF EE EE EE AA

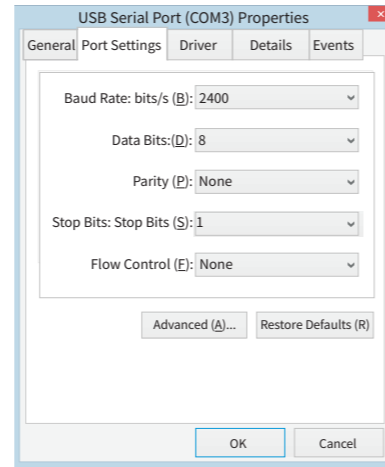
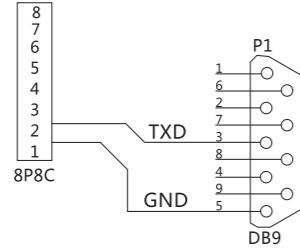

Note:

- When connecting RS232 or RS485, if the screen cannot be controlled to perform related actions, please swap the two control lines.
- The wiring loop resistance should be less than 20Ω.
- Do not run wiring parallel to strong interference sources.

Screen retraction height (lower limit) and extension height (upper limit) adjustment method:

● If it is necessary to adjust the limit height due to installation environment or other constraints, you can adjust the upper and lower limits by using the Limit Adjustment Tool provided. As shown in the following diagram:

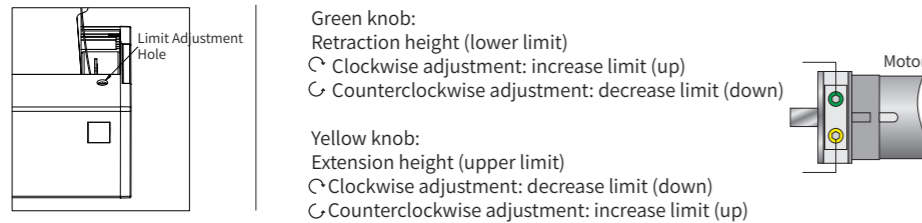

III.Maintenance

Ultra-short throw ambient light rejection fabric:DO NOT USE RAG OR PAPER TOWEL TO WIPE

- Use brush provided to brush lightly horizontally along the texture of the screen to remove dust or other fine particles.
- For light-colored smudges that affects viewing, try removing with residue-free tape.

Non ambient light rejection regular throw fabric:

Use clean water with mild detergent to gently wipe the stains on the surface of the fabric (do not use corrosive detergents).
Only retract the projection screen when the fabric is completely dry.

IV.Electrical parameters

Voltages & Frequencies: 110V/60Hz or 220V/50Hz(Actual voltage shall be subject to the electrical label shown on the product)

Wireless remote control (F): Voltage 3V, using battery CR2032X2, transmitting frequency; 868MHz, effective control distance is about 15 meters.

Troubleshooting

① Black grid fabric surface is carved with optical grating tooth, enabling the targeted reflection for ultra short throw projector light beam and forming the viewing image. Projection theory as below picture shown: Screen adsorbs only the ambient light from the top but resistance to ambient light from horizontal side will be weakened, please pay attention to the light beam direction when applied.

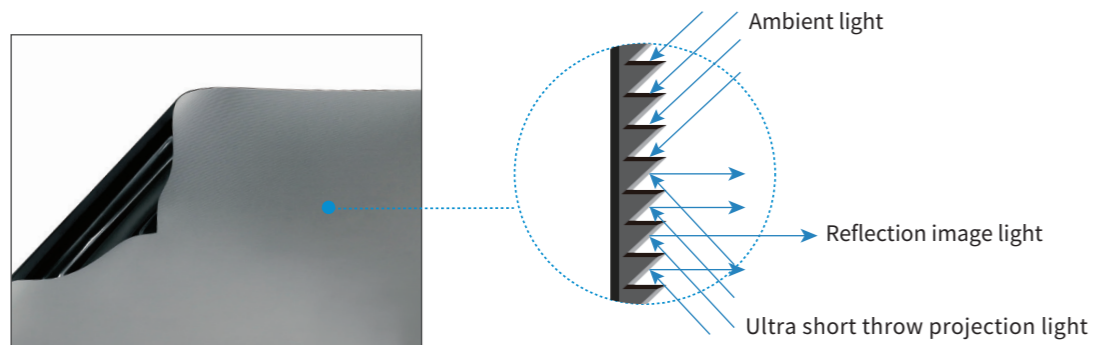

② The screen adopts the splicing process, and the splicing line has a certain curvature due to the source of upper and lower tension, which does not affect the actual projected picture, which is a normal phenomenon.

③ Fabric surface flatness: Lower black drop perfect range: 250-350mm

Motorized Tabletop Screen Installation Manual-III

Model:FC-FH-MFxxx II

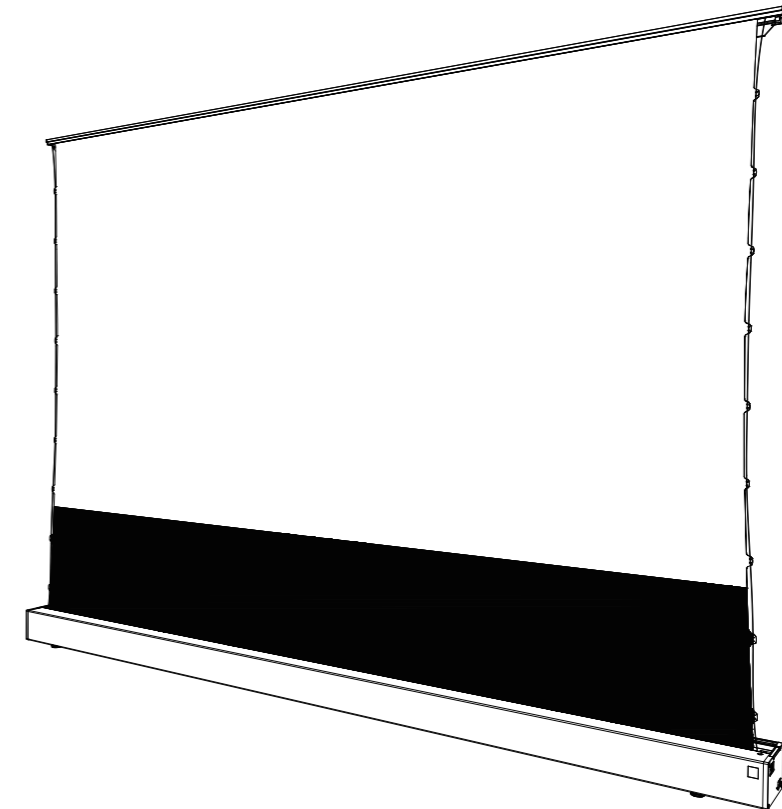

Caution

- Please tear out all the blue tape from the trap door before powering on.
- Please do not reach into the casing gap to prevent hands injury when the screen goes up.
- Please put the screen in place with no wind to prevent it from falling over.
- Please Do not disassemble or replace the original spare parts at will.

Thank you for choosing Gandview products. Please read the manual carefully before installation and use.

Screen structure diagram

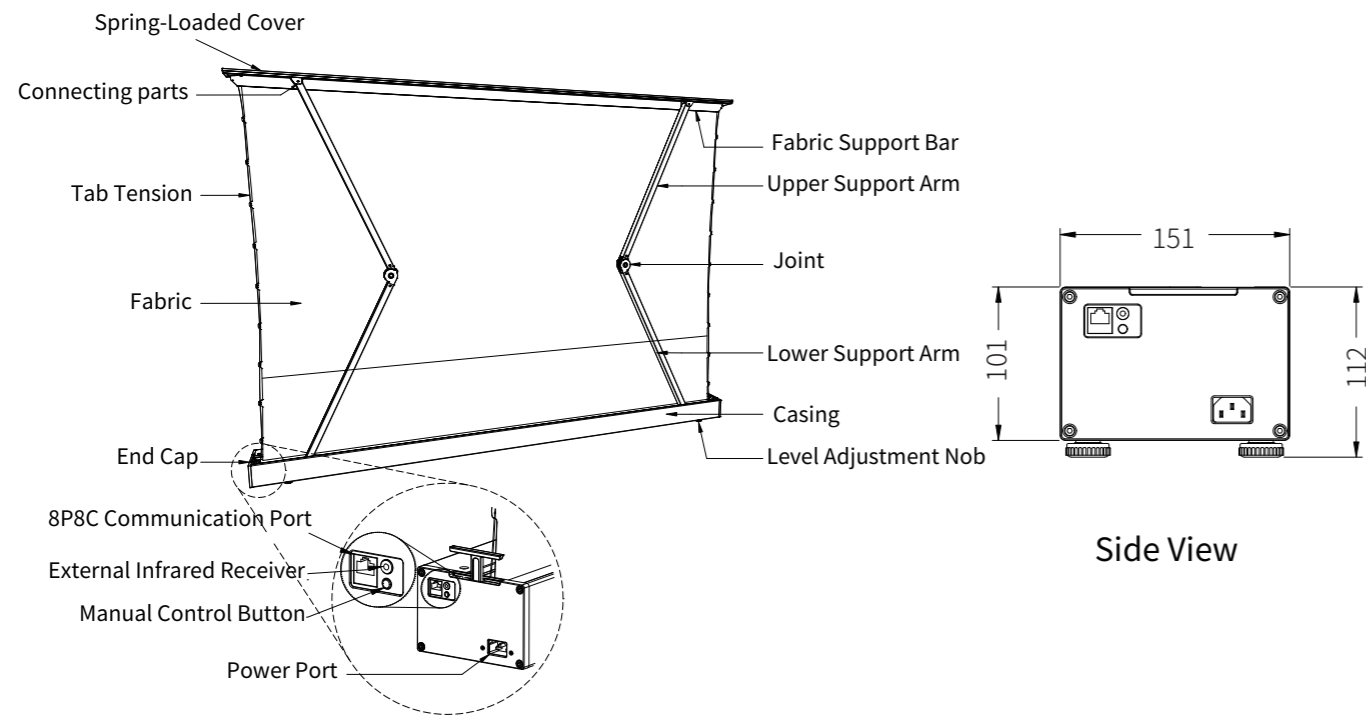

Accessories

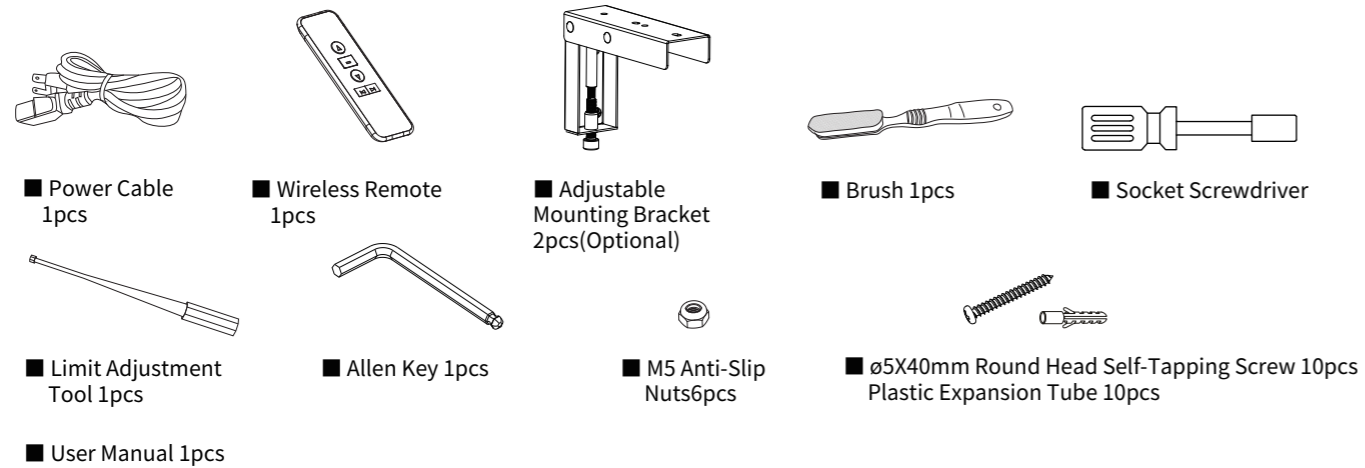

I .Screen Installation Guidelines

① Scenario 1

Lay the projection screen flat on the cabinet: leave at least 4mm of room from the wall. Fully extend the projection screen using the remote, adjust the tilt of the projection screen using the Level Adjustment Nobs under the casing.

Caution: Projection screen might tip over if there is too much tilt.

② Scenario 2

a.Measure the total length of the casing, measure the height where the bottom of the projection screen will be placed, and mark it on the wall. See value "A" on the table for the recommended distance between the two Adjustable Brackets. Line up the top of the Adjustable Bracket with the bottom of the projection screen (mark that was made on the wall).

b.Drill the 4 holes for each bracket on the wall, install an Expansion Fixture in each hole. Place the Adjustable Brackets against the wall lining up with the Expansion Fixtures and tighten using ø5*40 Tapping Screws.

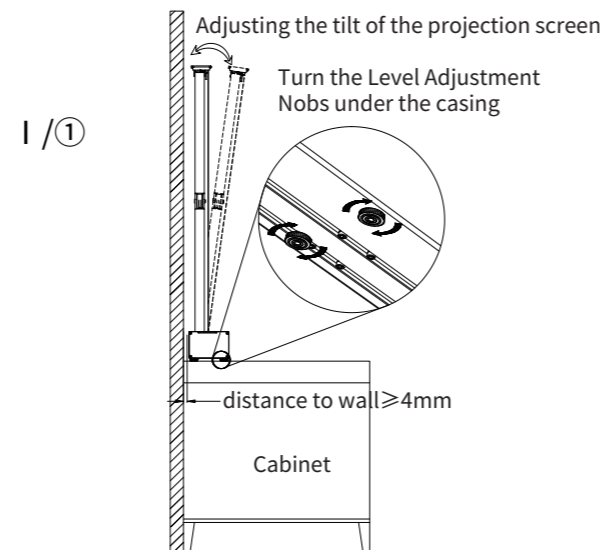

c.Adjust the T-Nuts on the Adjustable Bracket so that they are parallel with the wall (see diagram), place the projection screen on the Adjustable Brackets, adjust the projection screen horizontally to the desired position, tighten the T-Nuts from under the Adjustable Brackets to lock in place. (T-Nuts are installed for front installation in default, user can install the T-Nuts to the Reverse Mounting Holes when needed for reversed installation)

d.Connect to power, fully extend projection screen; observe for tilt, adjust tilt using the Allen Key to desired position to finish installation.

I / ② a-b

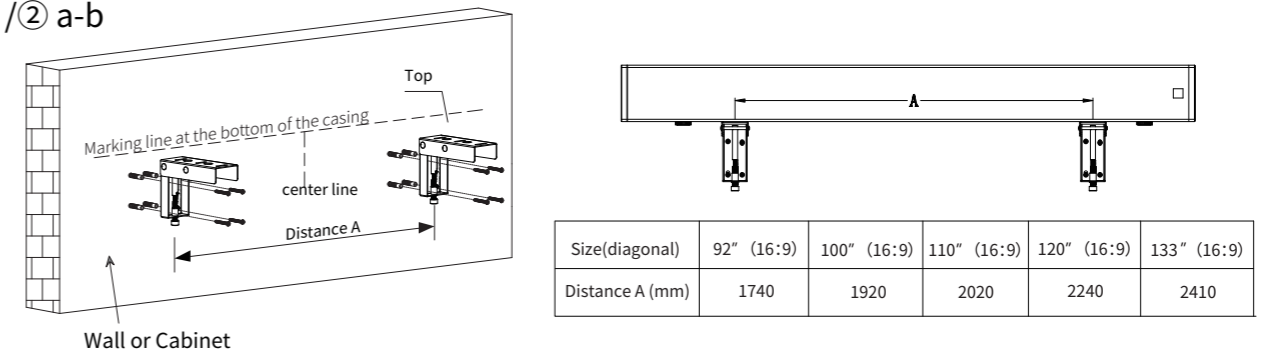

I / ② c-d

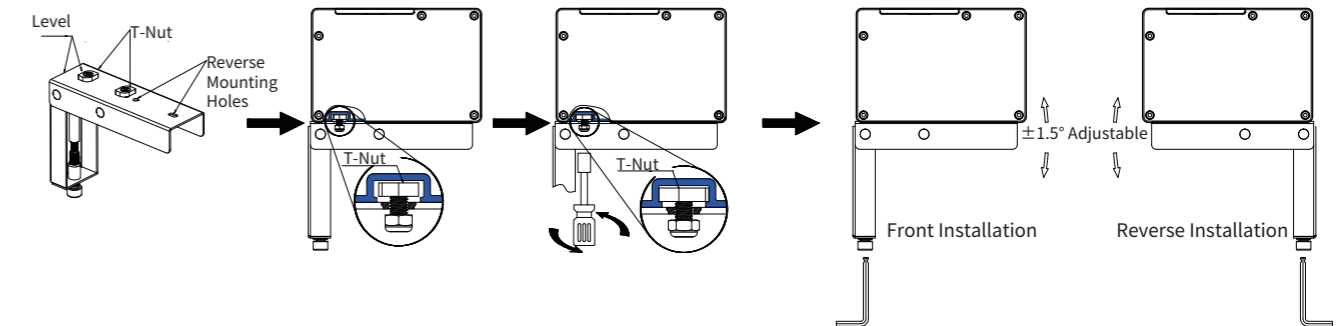

II .Functions and Instructions

This product has four control methods:

- Manual Control Button
- RF Remote Control
- RS485/RS232 Control
- Dry Contact

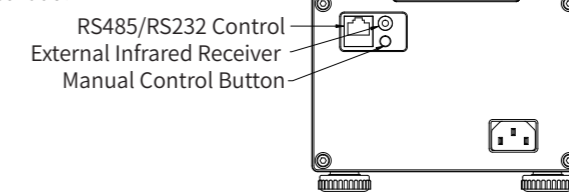

II / a

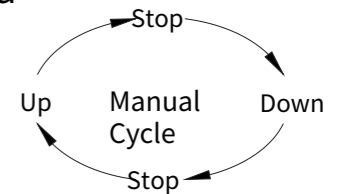

a.Manual Control

The Manual Control Button is located on the power port side of the casing. Pressing the button will command the screen to extend, pressing the button will command the screen to stop, then again to retract, then stop in sequence.

b.RF Remote Control

- Press the Up button, Decorative door opens, screen extends to set position.
- Press the Stop button, screen will pause.
- Press the Down button, the screen will retract and Decorative door closes.
- Press the Jog Up button or the Jog Down button to extend or retract the screen (usually used when setting extension or retraction limit).

Pairing/Unpairing(Remote have been paired at factory)

Disconnect the power supply for 10 seconds and then reconnect, press the Up and Stop button simultaneously within 10 seconds of reconnection. The motor will rotate forward and then backward once signaling a successful pairing. Repeat this process to unpair a remote. Repeat the process an odd number of times to pair, and an even number of times to unpair.

c.Dry contact control:

The control output port is connected to an RJ45 plug, with lines 4, 5, 7, and 8 being the control lines, starting from the left side.

Line	4	5	7	8
Function	Common	Up	Stop	Down

II / b

